

Accelerator Switch



ACCELERATOR PEDAL AND BRAKE PEDAL PREMO V1 + INTENSITY

The foot-pedal offers the latest development in technology and is a high-quality product for the operation of electrically driven vehicles in all sectors. The high level of safety category 2 with PL d EN ISO 13849 differentiates the pedal from competition.

- Safety category 2 with PL d EN ISO 13849
- Contact-less sensors
- Different output voltages available
- Sealed connection assembly, perfect for rough application conditions
- Electronic: protection class IP 65

Accelerator Switch

Dimensions [mm]

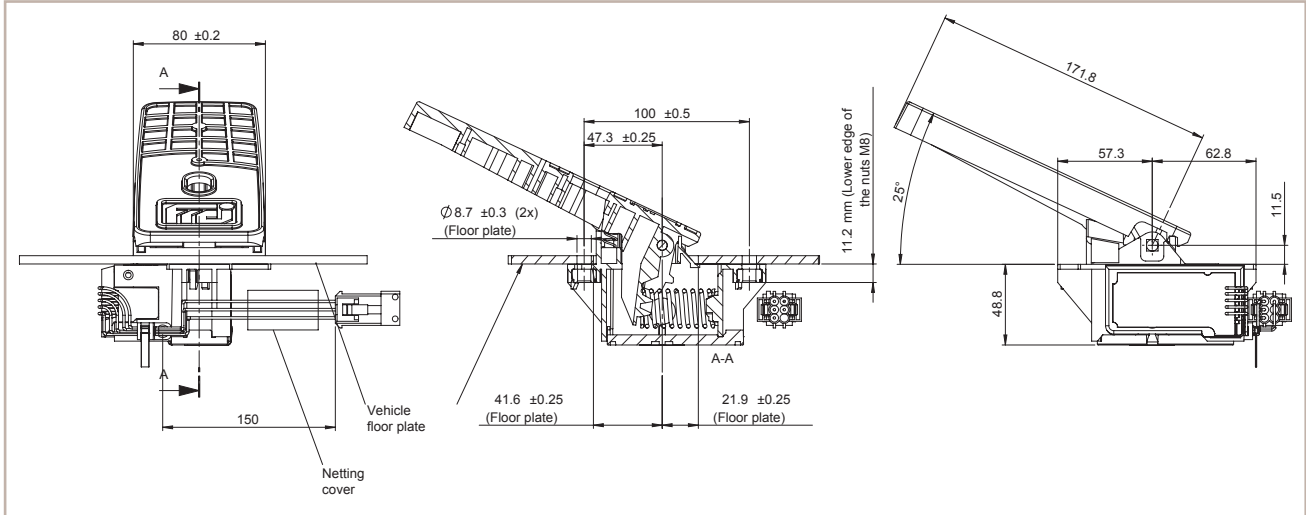

Technical Data

Operating voltage	see separate datasheet
Power consumption	see separate datasheet

Analogue output signal

Neutral position	1.5 V ± 0.3 V
End-point position	5.0 / 10.0 V ± 0.3 V
	see variants

Mechanical angle of rotation	approx. 15°
Electrical angle of rotation	approx. 3° – ca. 14°

Start signal

Voltage max.	35 V _{DC}
Current max.	25 mA
Switching point start signal	see separate datasheet

Digital Signals Low-Active

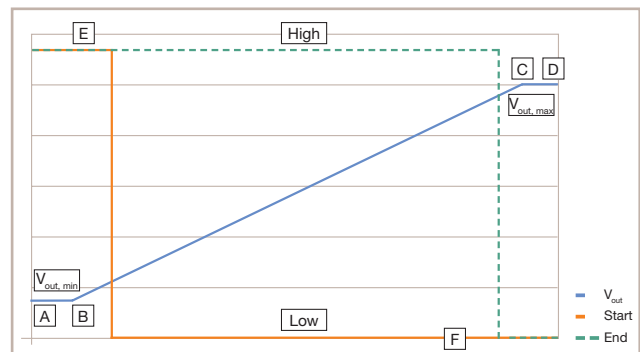

Different Accelerator and Brake Pedal Variants

Description	Accelerator pedal 12/10	Accelerator pedal 12/5	Accelerator pedal 24/5	Accelerator pedal 24/10	Brakepedal 12/10	Brakepedal 12/5	Brakepedal 24/5	Brakepedal 24/10
Part- No.	3103-00600-00	3103-00600-01	3103-00600-02	3103-00600-04	3103-00601-00	3103-00601-01	3103-00601-02	3103-00601-04
Operating voltage	12 V	12 V	24 V	24 V	12 V	12 V	24 V	24 V
Analoguesignal	1.5 – 10.0 V	0.3 – 5.0 V	0.3 – 5.0 V	1.5 – 10.0 V	1.5 – 10.0 V	0.3 – 5.0 V	0.3 – 5.0 V	1.5 – 10.0 V
Digital signals	Low active	Low active	Low active	Low active	Low active	Low active	Low active	Low active
Start / Stop								
PIN 1	GND	GND	GND	GND	GND	GND	GND	GND
PIN 2	+UB	+UB	+UB	+UB	+UB	+UB	+UB	+UB
PIN 3	V _{out} Accel. pedal	V _{out} Accel. pedal	V _{out} Accel. pedal	V _{out} Accel. pedal	–	–	–	–
PIN 4	Start signal	Start signal	Start signal	Start signal	Start signal	Start signal	Start signal	Start signal
PIN 5	End signal	End signal	End signal	End signal	End signal	End signal	End signal	End signal
PIN 6	–	–	–	–	V _{out} Brakepedal	V _{out} Brakepedal	V _{out} Brakepedal	V _{out} Brakepedal